

Bathroom Safety for Older People

Anna Cathryn Yost
Department of Consumer and Family Economics

James Martin
Physical Therapy Education

Home bathrooms often need adaptation if an elderly person wants to stay at home and remain independent. Ensuring bathroom access and safety may require room adaptations.

Bath

Falls often occur as people get in or out of the tub. Non-slip suction mats or rubber silicone appliques in the tub will help prevent falls.

A non-skid, latex-coated bath mat on the floor beside the tub provides firm footing.

Safety bars

Grab bars around the bathtub are a necessity for safety. These bars should be institutional-grade, stainless steel and installed according to the manufacturer's directions for firm, solid support. These bars are expensive, but under no circumstance should towel rods or improperly installed grab bars be used as bathtub aids. They will not support a person who loses balance.

Different types of bars and poles are available from plumbing supply companies. The type, number and positioning of supports depend on:

- The wall space around the tub;
- The wall structure;
- The plumbing arrangements; and
- The disability, if any, of the person(s) using the tub.

Two types of grab bars usually are needed at the tub for the ambulant older person:

- For use in getting in and out of the tub from a standing position;
- For use when lowering or raising the body to or from a seated position in the tub.

U-shaped bars are available in 12- to 40-inch lengths. They may be secured vertically or horizontally to a wall.

A vertically placed U-bar, attached to the side wall at the foot of the tub, allows safe entry and exit. (The foot of the tub is the end where the water faucets and drain are located). This vertical bar should be about 32 inches long, and placed near the outer tub edge.

Horizontally placed support bars are best for lowering or raising the body to or from the seated position in the tub. A 12- to 15-inch bar may be placed at the foot end of the tub and a longer one along the back wall.

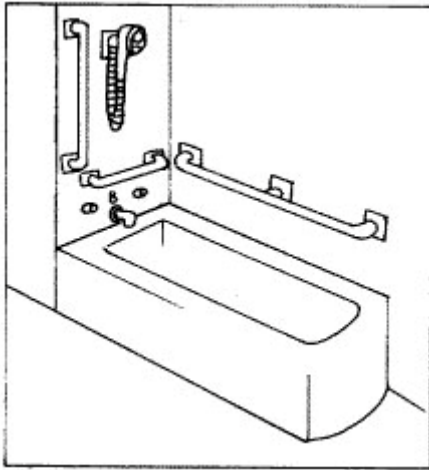

Figure 1
Horizontal bars.

Diagonally placed grab bars are not recommended because the hand may slide and if footing is not secure, falls are more likely.

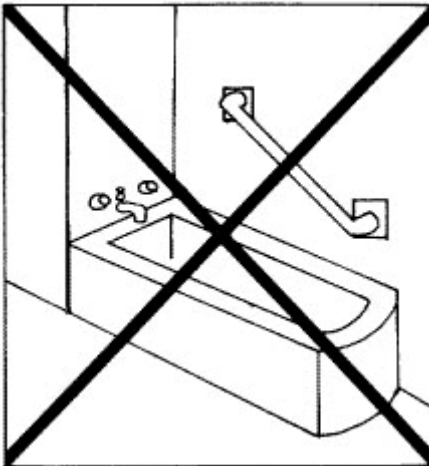

Figure 2
Diagonal bar.

If the tub is free-standing at both ends (as in many older homes) and the end wall is too far for grab bar placement, a vertically placed pole on the access side of the tub may be used. This pole should be about 1-1/2-inch diameter and extend from floor to ceiling. Position it between 1 foot 3 inches to 1 foot 6 inches from the end of the tub and close enough to the access side to reach from a seated position. It also can be used to grasp with one hand while operating the water controls.

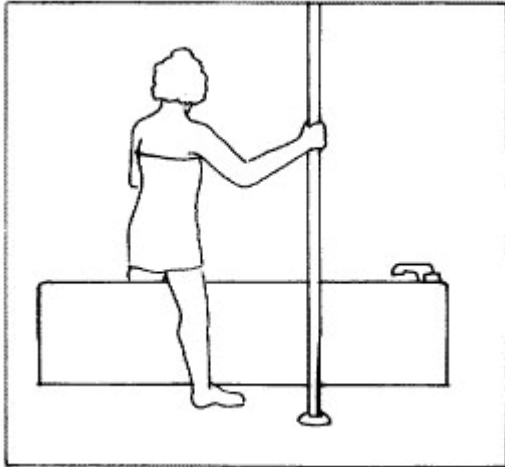

Figure 3
Vertical bar.

Angle bars from the back wall (behind the tub) to the floor, with wall posts, may be used when one or both tub ends are enclosed by a wall. This is useful for persons needing to use both hands to enter/exit the tub, or if other people with varying dysfunction's also use the tub.

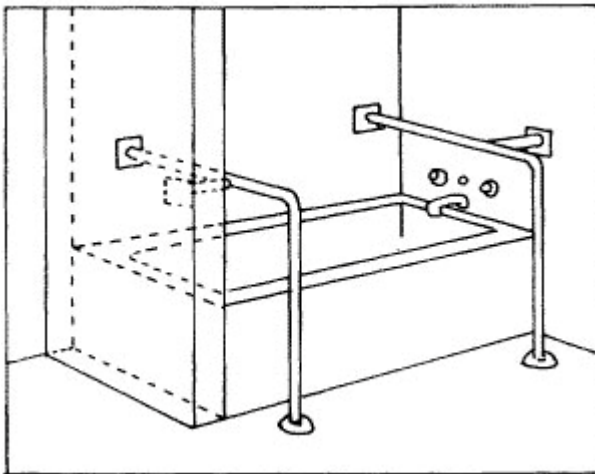

Figure 4
Angle bars.

Tub seats

A variety of portable seats, chairs and benches are available if sitting on the bathtub floor is difficult or impossible.

One seat has side flanges that adjust to fit any shape and size tub.

Inside-the-tub chairs with backs for greater comfort are available.

An inside/outside transfer bench with adjustable legs allows the bather to sit on the bench that extends outside the tub then slide to the inside of the tub.

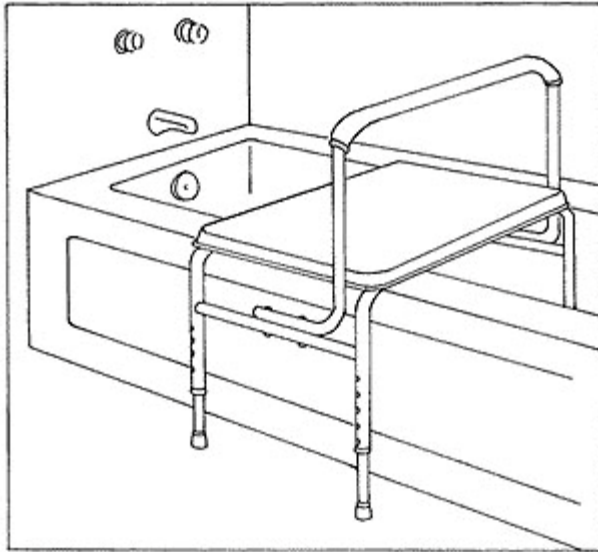

Figure 5
Transfer bench.

Any chair or bench must have non-slip rubber tips on the legs and be safe and comfortable.

When using these seats in the tub, a hand-held shower head is almost a necessity to direct the water where needed.

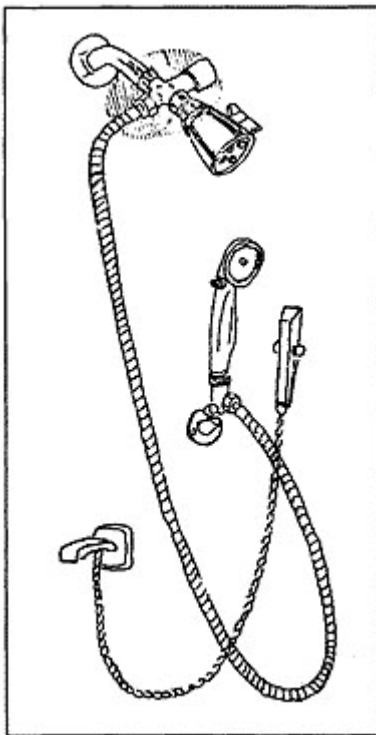

Figure 6
Flexible shower arm.

Showers

An angle bar attached to two walls provides support while standing to shower, or as an aid to sitting and rising if using a bath bench or chair.



Figure 7
Angle bar.

If the shower floor is slippery, nonslip suction mats or rubber silicone treads should be used.

A non-skid bath mat on the floor outside the shower is a necessity.

Toilets

The standard 15- to 17-inch height of toilet seats creates a problem for many people, especially those with arthritis, hip, knee or back problems. Elevating the seat from 5- to 7- inches will give better leverage in regaining a standing position.

There are several types of removable and permanently fixed raised toilet seats available from supply companies.

Two examples are

- A molded plastic seat is the simplest way to increase seat height by about 4 inches.



Figure 8 (left)
Molded plastic seat.

Figure 9 (right)
Adjustable seat.

- An adjustable seat will add from 3 to 6 inches of height.

For a more permanent raised toilet, a plumber can put the stool on a wooden platform made to fit the toilet bowl base.

If building a new bathroom, consider a wall-hung toilet that can be hung at any height.

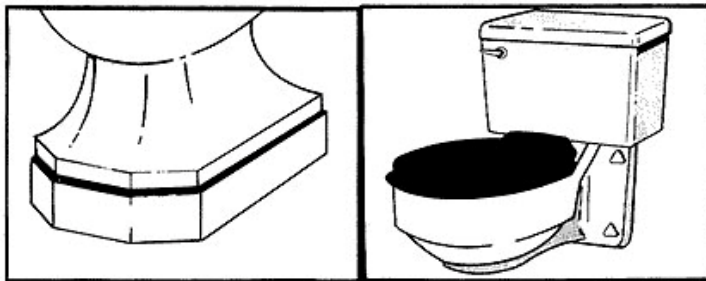

Figure 10 (left)
Raised toilet base.

Figure 11 (right)
Wall hung toilet.

Special feature

A special unit (portable bidet) for cleaning the perineal area without hands or paper may be attached to any standard toilet bowl. It is an electrically powered unit with a mechanism for spray washing with warm water and drying with a flow of warm air. This promotes independence for persons with very limited hand/arm functions.

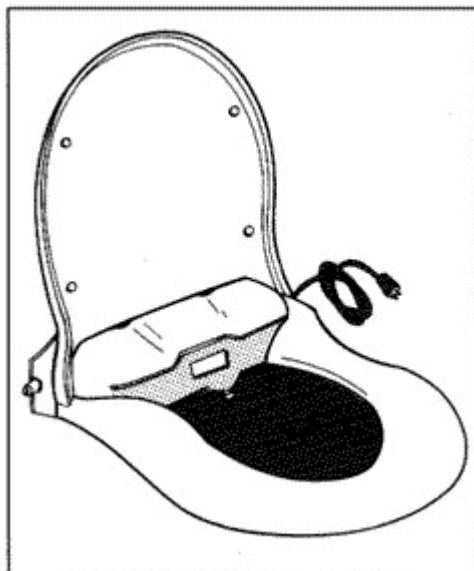

Figure 12
Portable bidet.

Grab bars

Grab bars around the toilets are for safety. Many types are available. The choice will depend on

- Available wall space near the toilet
- Nearness to other fixtures in the room
- Needs of people in the household

Basic types of toilet support bars include

- Wall-mounted on a side wall.



Figure 13
Side and back mounted bars.

- Wall-mounted on the back wall behind the toilet.
- Wall/floor mounted.

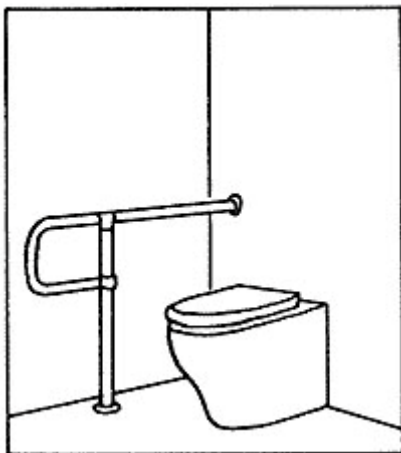

Figure 14
Wall/floor mounted.

- Free-standing.

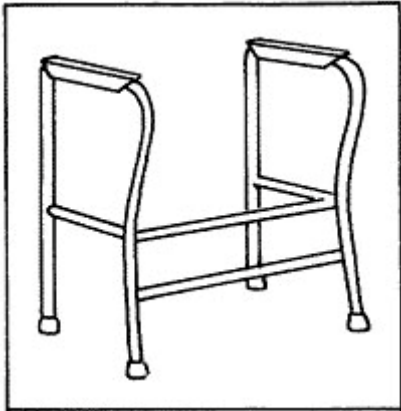

Figure 15
Free standing.

- Floor model.

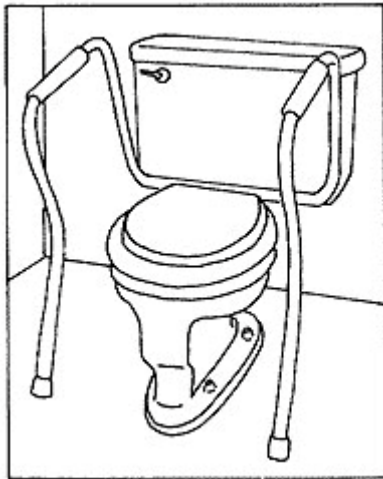

Figure 16
Free standing.

- Slip-over guard rails.



Figure 17
Slipover.

Other safety features

A single-lever mixing faucet can control temperature and flow of water better than dual controls. All hot water in the older person's home should be controlled thermostatically to a maximum temperature of 120 degrees to avoid burns.

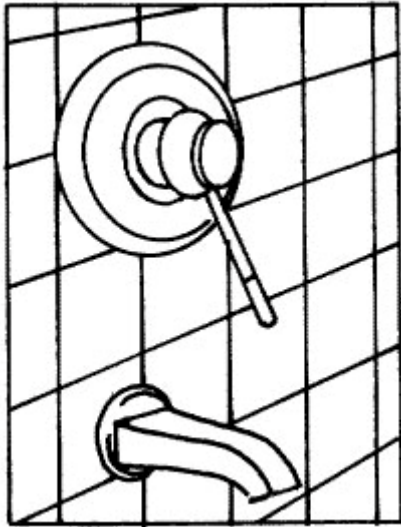

Figure 18
Single lever faucet.

Get Professional Help for Safety

- If you have a physical limitation, weakness or unsteadiness, we recommend you consult a physical therapist or the Housing Specialist in your local MU Extension center to help you select and recommend placement of grab bars and other accessories for safety in the bathroom.
- If you are unsure of your wall structure or do not have proper tools or skills we suggest you hire a carpenter to install and/or make the new adaptations.

Sources

- *Home Health Care Catalog*, Sears, Roebuck and Company (pick up at retail store). No charge.
- *J.C. Penney Catalog*. No charge.
- *FashionABLE Catalog*, Rocky Hill, New Jersey 08553. No charge.
- CLEO Living Aids, 3957 Mayfield Road, Cleveland, Ohio 44121. No charge.
- Fred Sammons, Inc., Catalog, Box 32, Brookfield, Illinois 60513-0032. Items from the Fred Sammons catalog may be ordered from the following:
 - Arthritis Foundation Self-Help Shop, 4144 Lindell, St. Louis, MO 63108, 800-392-7634
 - Doctor's Equipment Service, 6021 Troost, Kansas City, Missouri 64110, 816-523-6644

- Mr. Bidet Products Division, P.O. Box 1500, Hollywood, FL 33022